



POWERBOX³ UNITS

Safety, installation and
maintenance instructions



CONTENTS

PAGE

STANDARD VENTILATION FANS

1 SAFETY	4
2 INTRODUCTION & PURPOSE - GENERAL	4
3 STORAGE & HANDLING	5
4 MECHANICAL INSTALLATION	5
5 ELECTRICAL INSTALLATION & OPERATION	6
5.1 - OVERHEAT PROTECTION	7
5.2 - BEARING TEMPERATURE, VIBRATION & LEVEL MONITORING SENSORS	7
5.3 - ANTI-CONDENSATION HEATER	7
5.4 - SWITCH-ON	7
6 MAINTENANCE	8
6.1 - FIXINGS	8
6.2 - INFREQUENT USE	8
7 OVERHAUL / EXTENDED MAINTENANCE	9
8 FAULT FINDING	9
8.1 - ELECTRICAL	9
8.2 - MECHANICAL	9
9 DISPOSAL	10
10 EUROPEAN MACHINERY DIRECTIVE 2006/42/EC 10	10
DECLARATION OF CONFORMITY	10
EC DECLARATION OF CONFORMITY	11

TABLE

1 ROUTINE MAINTENANCE PROCEDURES12

FIGURES

1 WIRING DETAIL - SINGLE PHASE IEDXB20 DELTA 13
2 WIRING DETAIL - THREE PHASE FC 51 STAR 13
3 WIRING DETAIL - THREE PHASE FC IDDXF54 & IDDXF66 STAR 14
4 WIRING DETAIL - THREE PHASE DOL 15
5 TORQUE SETTING FOR FIXINGS 16

**THIS LEAFLET MUST BE PASSED TO THE USER
TO ENABLE THE FAN TO BE MAINTAINED IN A SAFE CONDITION.**

1. SAFETY

Warning and safety information relevant to specific operations are contained within each section. The following warning or advice categories are used:



DANGER! Failure to follow these instructions may result in serious injury or death to the user in addition to serious damage to the equipment.



WARNING! Failure to follow these instructions may result in minor injury or damage to the equipment.



CAUTION! Failure to follow these instructions may result in malfunction or damage to the equipment.



NOTE! Additional instructions to consider.

2. INTRODUCTION & PURPOSE - GENERAL

Woods' Powerbox³ units are high pressure air movement products with removable outlet panels to permit multiple outlet flow configurations. The design operating temperature range is -20°C extending to the upper temperature stated on the product nameplate.

Each assembly has been manufactured to suit the application for which it was designed. No deviation from the original construction must be implemented without referring to Woods Air Movement head office (located in Colchester in the UK). Any queries regarding safety or operating problems must be referred to your local Woods Air Movement office, sales centre or representative, together with full nameplate details. Should a failure occur whilst the product is under warranty, the Woods Air Movement service centre in Colchester must be contacted before any repair work is undertaken.

Only approved, qualified personnel familiar with the assessment of hazards and risks associated with fans, and with the use of tools and test equipment required to service such equipment, should install, operate and maintain the product. If the installer or user is unable to understand the information in this manual or has any doubt that safe and reliable installation, operation, and maintenance of the equipment can be assured, Woods Air Movement or their representative must be contacted for advice.

3. STORAGE & HANDLING



WARNING! When storing Powerbox³ units, please ensure that access by unauthorised personnel is prevented by using guards, barriers, or secure premises, so that fan impellers, which may be rotating (wind milling), do not present a hazard.

Check immediately on receipt that the product is as ordered and that it has not been damaged in transit.

Where the product is delivered in a crate (or similar) the crate must be considered as a protective device for transit only.

The crate must not have other equipment stacked on top of it and it must not be stacked on top of other equipment. The crate structure must not be used as a lifting aid, unless otherwise indicated.

Where a product is packed inside a crate, a fork-lift truck or similar must be used to transport the product. The product must be stored in a safe, clean, dry, vibration free location. If such storage conditions are not available, the motor anti-condensation heater (where fitted) should be connected to an appropriate electrical power supply to prevent motor condensation forming, while the product should be stored in an appropriate enclosure. Each month, the fan impeller should be given a manual rapid spin to help prevent grease from hardening and possible bearing brinelling. The impeller must not remain in the same angular position after rotation.

When dismantling the crate to gain access to the product care must be taken to avoid injury from sharp edges, nails, staples, splinters, etc.

If the product is to be stored for 12 months or more then the activities described in Section 6.2 should be carried out. It is highly recommended that the product is inspected by a member of the Woods Air Movement service team before commissioning is undertaken.

4. MECHANICAL INSTALLATION



DANGER! It is recommended that suitable safety guards form part of the installation. Advice on these, and similar safety devices, are available from Woods Air Movement.



WARNING! Where the product is delivered in a crate (or similar), the crate must be considered as a protective device only and must not be used as a lifting aid unless clearly indicated otherwise.



WARNING! All lifting aids used during installation must be appropriately certified to carry the weight of the equipment being lifted.



WARNING! The correct protective clothing (including hard hats, eye protectors and ear defenders) should always be worn when working with and in the vicinity of the fan assembly.



WARNING! During lifting of the fan all personnel must be clear of the area below and around the suspended unit.



NOTE! Before installation, check that no damage has occurred in transit, that there is no fan casing deformation, that the impeller rotates freely and that the nameplate data complies with its required use. If the product has been stored for longer than a month, please refer to Section 6.2.

Powerbox³ units can sometimes be very heavy (depending on fan and motor size and any attached ancillary equipment), which can make them unwieldy during handling. They must therefore be lifted slowly to prevent damage or distortion. Proper precautions must be taken and certified lifting aids used to ensure that the product is well supported and stable before lifting into position. Care must be taken when installing the equipment to ensure that the product orientation is correct in relation to direction arrows which indicate direction of air movement and impeller rotation.

Sharp bends in the ductwork close to the product must be avoided. Adequate room must be allowed around the unit for inspection and maintenance. When ancillary components are used with the products, such as anti-vibration mounts, attenuators, air operated dampers, flexible connectors (and their clips), weather proofing, platforms, supports, chains, and harnesses, etc., they must be fully aligned before being bolted together so that no distortion or stress is placed on the equipment. Connections between ductwork and the product must be suitably sealed to control egress of internal residues and ingress of external weather conditions. When units are installed outside of a building, appropriate weather proof ancillary components should be installed.

The mounting and support structure must be strong and rigid enough to take the weight and operating forces of the product and any other weight applied during installation. Consideration must be given to mitigation of vibration transmission. If vibration isolators are used they must be appropriate for the weight and thrust of the unit and must not be used to compensate for misaligned component fixing points. If any component parts do not easily fit together the root cause must be investigated and rectified.

Provision for drainage is provided in each motor. The motor drain hole must be located at the lowest point of the motor when the product is installed. In situations where the ambient conditions are humid and the motor is not operated, periodic inspections should be carried out to ensure there is not a general build up of condensation. The frequency will depend on environmental conditions and should be recorded within maintenance records. To maintain the IP rating drain plugs must not be permanently removed.

After installation all packing materials must be disposed of in accordance with the instructions advised in Section 9.

5. ELECTRICAL INSTALLATION & OPERATION



DANGER! Before any work can be attempted, the Powerbox³ unit and all controls must be completely isolated from electrical supplies. Ensure that rotating parts are fully at rest.



WARNING! Before entering the area where the product is installed, please ensure that all fumes, dust, toxic emissions, heat etc. have dispersed from the local environment, and that the fan blades are not likely to rotate.



DANGER! The fan assembly contains rotating parts and electrical connections which can be a danger and cause injury. If there is any doubt that a safe and reliable fan installation can be achieved Woods Air Movement or their representative must be contacted for advice.



WARNING! Always wear appropriate protective clothing (including hard hats, eye protectors and ear defenders etc.) when working in the vicinity of the fan assembly.

Some Powerbox³ units can only be operated through a pre-programmed speed control drive provided with the product. This will be indicated on the nameplate and datasheet. Dual supply products can be operated through a speed control drive or at a fixed speed via a direct on line starter panel. The starter panel must be suitably rated for the starting current displayed on the nameplate.

The electrical supply and electrical earthing must be connected to the terminal box by a qualified and competent electrician. It is good practice to fit a clearly marked isolator switch close to the product, preferably of the lockable type which will allow the operator or maintenance engineer to isolate the product from the electrical supply before working on the assembly. Alternatively, we recommend the use of a second clearly marked and accessible switch remote from the product to provide an enhanced level of safety when isolating the product during maintenance.

Electrical control circuit fuses must be correctly selected to carry the rated starting current but should only be regarded as offering protection against wiring short circuits or earth faults. Fuses are not intended to provide overload protection. To provide full protection for the equipment, overload protection must be installed.

A connection diagram providing wiring details is shown in Figures 1-4.

Sufficient cable length must be provided to allow for movement of the product on its mountings.

Products with a motor-mounted terminal box must have the electrical supply routed through a gland assembly in the designated side panel to the entry point in the side of the motor terminal box, using the motor support to secure the cable. Cables must be routed via a gland assembly which should be tightened sufficiently to hold the cable and provide a weatherproof seal, but it must not be over-tightened.

5.1 OVERHEAT PROTECTION

Motor overheat protection (if fitted) can be enabled through the use of an appropriate relay to control the motor stop/start function.

When a motor cools down, an over-heat protection device will reset. However the motor must not be allowed to start until the motor start contactor is manually reset.

5.2 BEARING TEMPERATURE AND VIBRATION MONITORING SENSORS

If the control system makes use of monitoring sensors, then they must be wired to automatically switch the product off if a fault occurs, or to provide a fault indication. If the product is automatically switched off by a monitoring sensor then the control system must ensure that the product remains isolated from the electrical supply, so that it will not automatically reset and re-start.

5.3 ANTI-CONDENSATION HEATER

Anti-condensation heaters (if fitted) are terminated in a terminal box and must be externally wired to automatically receive the appropriate electrical supply when the motor is switched off. When the motor is switched on the anti-condensation heater is not required and thus must be automatically switched out of circuit.

5.4 SWITCH ON

Before switching on:

- confirm that the electrical supply is fully compliant with the requirement of the Powerbox³ motor and speed control drive as detailed on the nameplate and ensure that all electrical connections are terminated correctly,
- confirm that the product is correctly installed,
- confirm that all component parts and fixings are secure,
- confirm that safety guards are in place,
- confirm that no loose items or associated equipment are present in the vicinity.

Immediately after switch-on check that the rotation direction is correct,

- if the rotation direction is incorrect, then this can be rectified by interchanging any two incoming phase connections of the U, V, W or L1, L2, L3 leads at the motor terminal block. Please refer to relevant wiring diagram,
- check the assembly for smooth, low vibration running,
- check that the current consumption is within the full load current specified on the nameplate,
- the motor must not be repeatedly or rapidly switched on and off as this could cause overheating of the motor or its associated wiring connections.

5.5 OPERATION

Products must not be operated above their maximum indicated speed or run where the fan is operating in a stalled condition.

Products must not be run in reverse.

6. MAINTENANCE



DANGER! Before any maintenance work can be attempted, the Powerbox³ assembly, its anti-condensation heater (if fitted), and all controls from electrical supplies must be completely isolated. Ensure that rotating parts are fully at rest.



WARNING! Before entering the area where the product is installed, please ensure that all fumes, dust, toxic emissions, heat etc. have dispersed from the local environment, and that the impeller blades are not likely to rotate.



WARNING! All lifting aids used during maintenance, and all lifting points utilised, must be adequately certified to carry the weight of the equipment being lifted.



WARNING! Always wear appropriate protective clothing (including hard hats, eye protectors and ear defenders etc.) when working in the vicinity of the fan assembly.

Maintenance must be carried out by appropriately qualified and competent personnel using the correct tools and equipment. A regular maintenance schedule should be established, and a record kept. It is recommended that the maintenance activities given in Table 1 are followed. Maintenance records are required to be documented throughout the warranty period.

Where the environment is particularly dirty, it may be necessary to reduce maintenance / service intervals. Internal and external surfaces may be cleaned with low pressure clean water and non-abrasive additives. Water or liquid cleaning agents must not be directed at motor drain holes, as this could cause liquid ingress.

After maintenance has been conducted and before the product is re-started, always ensure that there are no loose items of equipment present in the vicinity of the product, that all safety guards, chains, or steel ropes, etc., are properly secured into their original location, and that any temporary device used to stop the impeller blades from rotating has been removed.

6.1 FIXINGS

It is essential to ensure that all product assembly fixings are secure. When examining and checking the security of fixings during routine maintenance (see Table 1 Items 6, 9, 10 and 11), any fixings which have locking devices fitted or are painted over need not be disturbed if it can be seen that they are secure. Any locking devices that are disturbed during maintenance must be discarded and replaced with new identical devices. Thread forming screws must have locking compound applied when being reused. Any fixings which have no locking devices fitted and are not painted over, must be checked at 95% of their original torque setting to ensure that no unnecessary disturbance of the fixing has occurred. See Figure 5 for torque setting details. If in doubt, please contact Woods Air Movement for advice in relation to specific fixing torque values.

6.2 INFREQUENT USE

If the product is used less frequently than once a month, the following additional maintenance procedures must be out and a record kept:

- Resistance of motor windings to earth, must be measured using a 500V DC insulation tester each month. If these readings are less than 10 MΩ (Megaohm), the motor must be dried out in a warm airflow (typically at 40°C) and re-checked before running the motor.
- The product should be operated between 15 and 30 minutes each month to ensure that correct lubricant conditions are maintained within the bearings (i.e., to prevent grease hardening).
- If anti-condensation heaters are fitted, check each month that they automatically switch on (i.e., they are drawing current) when the motor is switched off.

7. OVERHAUL / EXTENDED MAINTENANCE

Advice on motor overhaul procedures, bearing /seal replacement, motor replacement, motor rewinding, spare parts, condition monitoring, vibration analysis, refurbishment, etc. is available from Woods Air Movement service centre in Colchester.

After 40,000 hours of running, we strongly recommend that a qualified and competent electrician performs a motor "health check" (as described within Section 8, Fault Finding) to determine the motor insulation condition.



NOTE!

The motor manufacturer's specification sheets are available through Woods Air Movement. After overhaul/extended maintenance the fan assembly must be correctly installed back into its original position.

8. FAULT FINDING

Please refer to the safety warnings ("attention" items) stated within Section 1 and 6.



NOTE!

Routine maintenance procedures detailed in Section 6, and Table 1 of this document are designed to help keep your fan operational and fault free.

8.1 ELECTRICAL

Check that electrical connections to the product and speed control drive are secure and are in accordance with the wiring connection diagram.

Check that the voltage applied at each electrical terminal is as specified on the nameplate and is balanced. Measure the current on each phase of the motor in turn and check that the current consumption is within the full load current specified on the nameplate.

Measure each motor winding to earth, and between each winding, using a 500V DC insulation tester. If the reading is less than 10 MΩ the reason is likely to be dampness within the motor. To dry out the motor place it in a warm dry airstream (typically at 40°C) and regularly monitor the motor until the insulation reading is restored to 10 MΩ or greater. If the reading remains at less than 10 MΩ, then this could indicate that a break-down in motor winding insulation has occurred, which may require the motor to be either rewound/overhauled.

If a smell of burnt motor insulation is detected, do not operate the equipment and seek immediate advice from Woods Air Movement Colchester.

8.2 MECHANICAL

Check that there are no obstructions to the motor shaft or impeller blades, that the blades are clean, and that there are no loose components, items, or debris in the vicinity.

Rotate the motor shaft by hand. Investigate any grinding noises, internal chafing, rubbing or stiffness. If any of these defects are observed, this may indicate that bearings require lubrication or replacement.

Ensure that all fixings are secure and tightened to the correct torque values.

9. DISPOSAL



NOTE!

Metal components of the fan/motor should be segregated and separately recycled. The following items of material should be safely disposed of in accordance with local health and safety regulations:

- electrical lead coverings,
- motor winding insulation materials,
- bearing lubricant,
- motor/fan terminal block,
- paintwork,
- plastic parts,
- packing materials,
- silencer infill



WARNING! A face mask and gloves must be worn when handling the infill. If the infill is particularly dry or is damaged it should be damped down before disposal.

10. DECLARATIONS OF CONFORMITY



EC Declaration of Conformity

Herewith we declare that the air movement equipment designated below, on the basis of its design and construction, in the form brought on to the market by us, is in accordance with the relevant health and safety requirements of the **EC Council directives on Machinery and Electromagnetic Compatibility and also ecodesign requirements for energy-related products.**

If alterations are made to the machinery without prior consultations with us, this declaration becomes invalid. We further declare that the equipment identified below may be intended to be assembled with other equipment/machines to constitute machinery, which shall not be put into service until the assembled machinery has been declared in conformity with the provisions of these EC Council directives.

Designation of equipment:

Series / type:

Fläkt Woods Limited order no: / 0

Relevant EC Council directives: Machinery Directive (2006/42/EC).
Electromagnetic Compatibility Directive (2014/30/EU) where applicable (1)
Energy-related products Directive (2009/125/EC) relevant implementing measures:
REGULATION (EU) No 327/2011, REGULATION (EU) No 1253/2014, where appropriate

Applied harmonized standards in particular (2): EN ISO 12100:2010, EN 60204-1:2018, EN ISO 12499:2008, EN ISO 5136:2010
EN ISO 5801:2017, EN ISO 13350:2015, EN IEC 61000-6-2:2019, EN 61000-6-1:2007
EN 61000-6-3:2007/A1:2011/AC:2012, EN 61000-6-4:2007/A1:2011

Applied national standards and technical specifications in particular (3): BS 848.2-1:2004 (BS ISO 13347-1:2004/A1:2010)
BS 848.6:2003 (BS ISO 14695:2003)
BS 848.7:2003 (ISO 14694:2003/A1:2011)

Basis of self attestation: Quality Assurance to BS EN ISO 9001:2015
BSI Reg Firm Cert No. FM 155.

Technical file compiled by: Ömer Tüzer
FläktGroup Holding GmbH, Bahnhofstr. 65-71, 44623 Herne, Germany

Signed for and on behalf of the manufacturer by:

Place: Colchester
Date: 03/10/2023

Position of signatory: Stéphane Maravel
Chief Officer Woods

Notes:

- (1) Fläkt Woods fans are driven by AC induction motors which are inherently compliant if supplied with a truly sinusoidal AC supply. Where the fan motor is supplied via an inverter or other electronic control, verification of its compatibility together with cabling should be sought from the control supplier.
- (2) For a complete list of applied standards and technical specifications see Fläkt Woods documentation.
- (3) Where no relevant harmonised standards exist.

Fläkt Woods Limited t/a Woods Air Movement

Axial Way
Colchester CO4 5ZD
United Kingdom
Tel: +44 (0) 1206 222555
Email: customerservices.woods@flaktgroup.com
Website: www.woodsairmovement.com

Registered in England no. 233771
Registered office: Axial Way, Colchester, CO4 5ZD, United Kingdom
© Fläkt Woods Limited October 2023





UKCA Declaration of Conformity

Herewith we declare that the air movement equipment designated below, on the basis of its design and construction, in the form brought on to the market by us, is in accordance with the relevant health and safety requirements of the **UK Parliament Regulations on Product Safety, Electromagnetic Compatibility and Ecodesign for Energy-Related Products**. If alterations are made to the machinery without prior consultations with us, this declaration becomes invalid. We further declare that the equipment identified below may be intended to be assembled with other equipment/machines to constitute machinery, which shall not be put into service until the assembled machinery has been declared in conformity with the provisions of these UK Parliament Regulations.

Designation of equipment:

Series / type: **PowerBox³**

Fläkt Woods Limited order no:

Relevant UK Regulations:

Supply of Machinery (Safety) Regulations 2008
Electromagnetic Compatibility Regulations 2016 where applicable (1)
Ecodesign of energy-consuming products relevant implementing measures:
REGULATION (EU) No 327/2011, REGULATION (EU) No 1253/2014, where appropriate

Designated standards
in particular (2):

EN ISO 12100:2010, EN 60204-1:2018, EN ISO 12499:2008, EN ISO 5136:2010
EN ISO 5801:2017, EN ISO 13350:2015, EN IEC 61000-6-2:2019, EN 61000-6-1:2007
EN 61000-6-3:2007/A1:2011/AC:2012, EN 61000-6-4:2007/A1:2011
BS ISO 13347-1:2004/A1:2010, BS ISO 14694:2003/A1:2011,
BS ISO 14695:2003

Basis of self attestation:

Quality Assurance to BS EN ISO 9001:2015
BSI Reg Firm Cert No. FM 155.

Technical file compiled by:

Iain Kinghorn
Fläkt Woods Limited, Axial Way, Colchester, CO4 5ZD, United Kingdom

Signed for and on behalf of the
manufacturer by:

Place: Colchester
Date: 06/10/2023

Position of signatory:

Stéphane Maravel
Chief Officer Woods

Notes:

- (1) Fläkt Woods fans are driven by AC induction motors which are inherently compliant if supplied with a truly sinusoidal AC supply. Where the fan motor is supplied via an inverter or other electronic control, verification of its compatibility together with cabling should be sought from the control supplier.
- (2) For a complete list of applied standards and technical specifications see Fläkt Woods documentation.

Fläkt Woods Limited t/a Woods Air Movement

Axial Way
Colchester CO4 5ZD
United Kingdom
Tel: +44 (0) 1206 222555
Email: customerservices.woods@flaktgroup.com
Website: www.woodsairmovement.com

Registered in England no. 233771
Registered office: Axial Way, Colchester, CO4 5ZD, United Kingdom

© Fläkt Woods Limited October 2023



TABLE 1

Routine Maintenance Schedule	Every 6 Months	Every 12 Months	Comments
1. Examine fan guards (if fitted)	<input type="checkbox"/>		Remove any debris that may have accumulated round or on the guard surface.
2. Examine motor cooling fins	<input type="checkbox"/>		Remove any material or dirt which has build-up between the motor cooling fins.
3. Examine impeller for dirt build-up or any physical damage	<input type="checkbox"/>		Remove any build-up of dirt. Ensure impeller is secure. Replace impeller if it is damaged.
4. Check condition and tautness of fan safety support chains/harnesses/ropes (if fitted)	<input type="checkbox"/>		Clean and inspect safety supports. Replace if there is any deterioration / corrosion detected.
5. Examine and operate vibration sensors (if fitted), and temperature sensors (if fitted)	<input type="checkbox"/>		Check operation using built-in sensor test features or dummy signals. Check that the fan is automatically switched off, or that a warning indication is provided, when the sensors / switches indicates a fault.
6. Examine condition of safety guards (if fitted) and associated fixings	<input type="checkbox"/>		Clean safety guards. Replace if there are any signs of excessive corrosion or damage.
7. Check Operation of anti-condensation heaters (if fitted)	<input type="checkbox"/>		Switch off power to the motor. Check that the anti-condensation heater is energised (i.e. it is drawing current).
8. Examine the clearance between the impeller and stationary inlet piece		<input type="checkbox"/>	Ensure that the gap between the impeller and the inlet cone is even and adequate. If in doubt, please contact Woods Air Movement for advice related to running clearance.
9. Check torque of fixings used to secure the fan to its support structure		<input type="checkbox"/>	It is essential to confirm that all fixings are properly fitted, are tight, and are fully driven home (see Section 6.1). If in doubt, please contact Woods Air Movement for advice related to the torque value of a particular fixing.
10. Examine motor, fan and ancillary equipment fixings		<input type="checkbox"/>	It is essential to confirm that all fixings are properly fitted, are tight, and are fully driven home (see Section 6.1). If in doubt about the torque of a fixing contact Woods Air Movement for advice.
11. Check movement (deflection) of vibration isolators (if fitted)		<input type="checkbox"/>	Check freedom of movement. Tighten anti-vibration mount fixings if necessary.
12. Check motor voltage and current consumption		<input type="checkbox"/>	Ensure voltage and full load current are as specified on the motor nameplate.
13. Inspect paintwork / galvanising finish		<input type="checkbox"/>	Treat any areas of damage with suitable anti-corrosion paint.
14. Grease motor bearings		<input type="checkbox"/>	If applicable, check requirement in accordance with Section 6.2
15. Check fan assembly wiring		<input type="checkbox"/>	Check security and condition of all wiring (including the earth).
16. Check product operation for excessive vibration levels		<input type="checkbox"/>	Vibration levels, whilst the product is operating, should not be excessive. If levels are seen to have increased since the previous inspection, the product must not be operated until the root cause has been identified and rectified.

FIGURE 1

SINGLE PHASE DELTA - IEDXB20, FC51

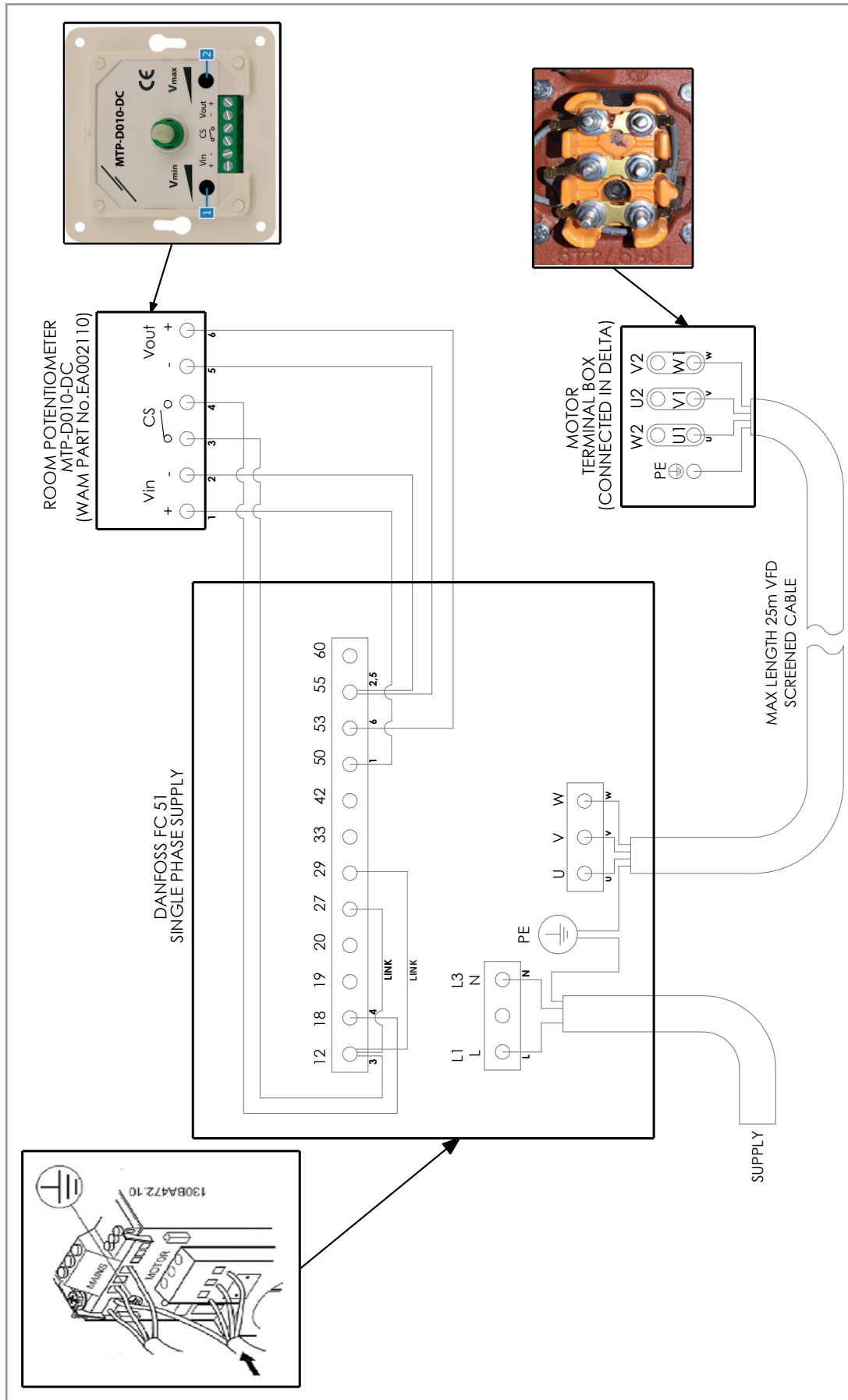

FIGURE 2

THREE PHASE STAR - FC 51

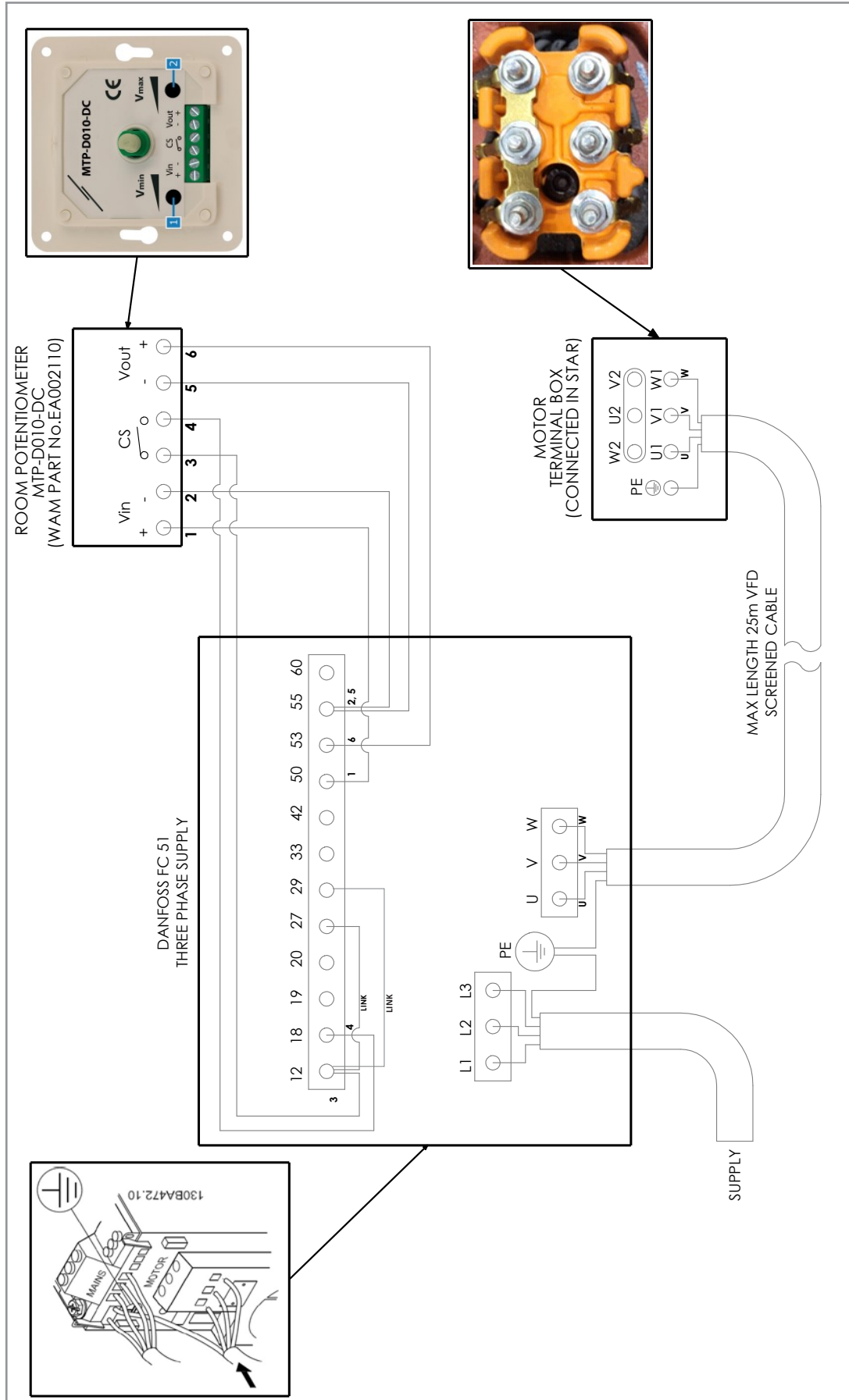

FIGURE 3

THREE PHASE STAR - IDDXF54, IDDXF55, IDDXF66, FC 101 & FC 102

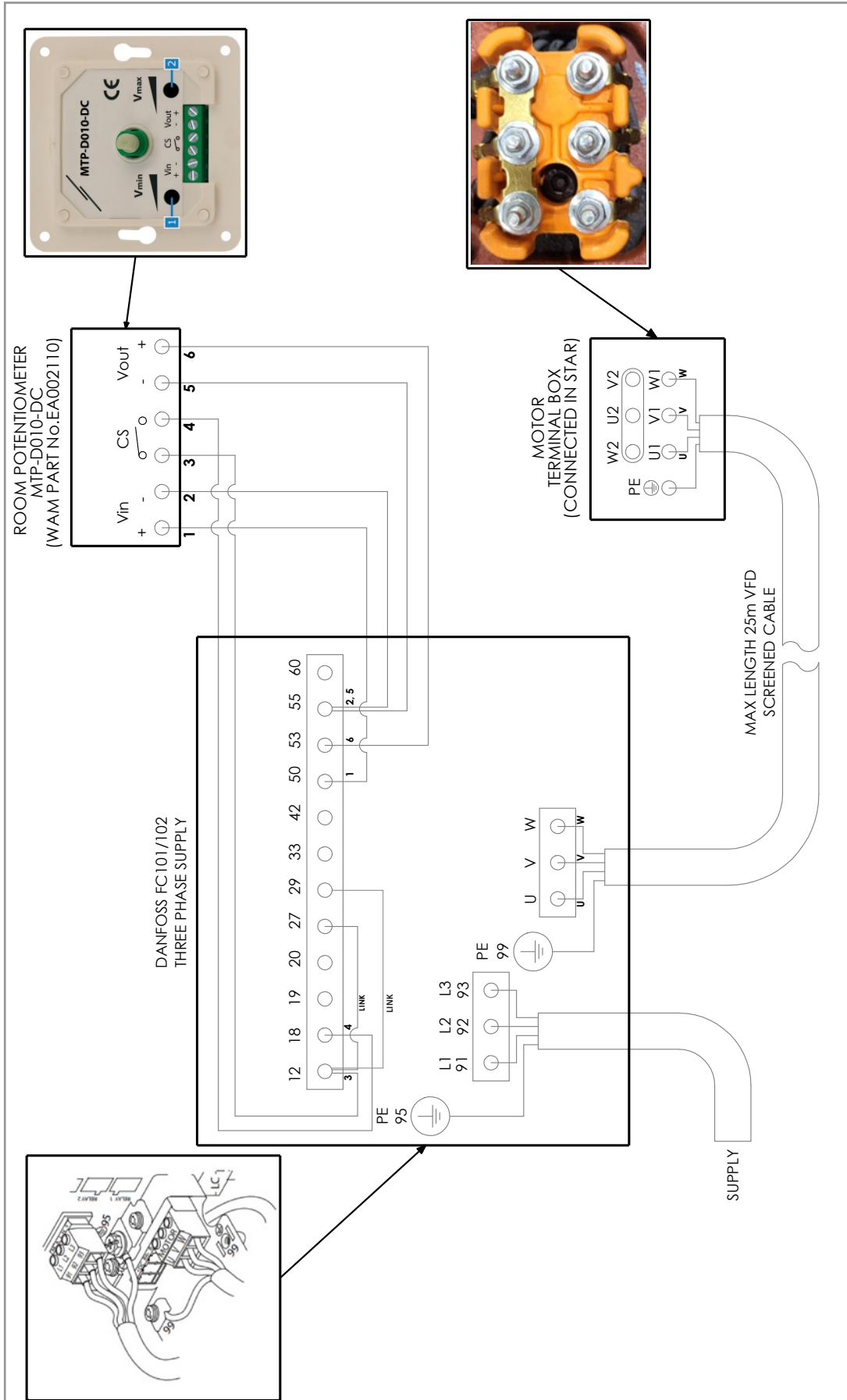

FIGURE 4

THREE PHASE DOL

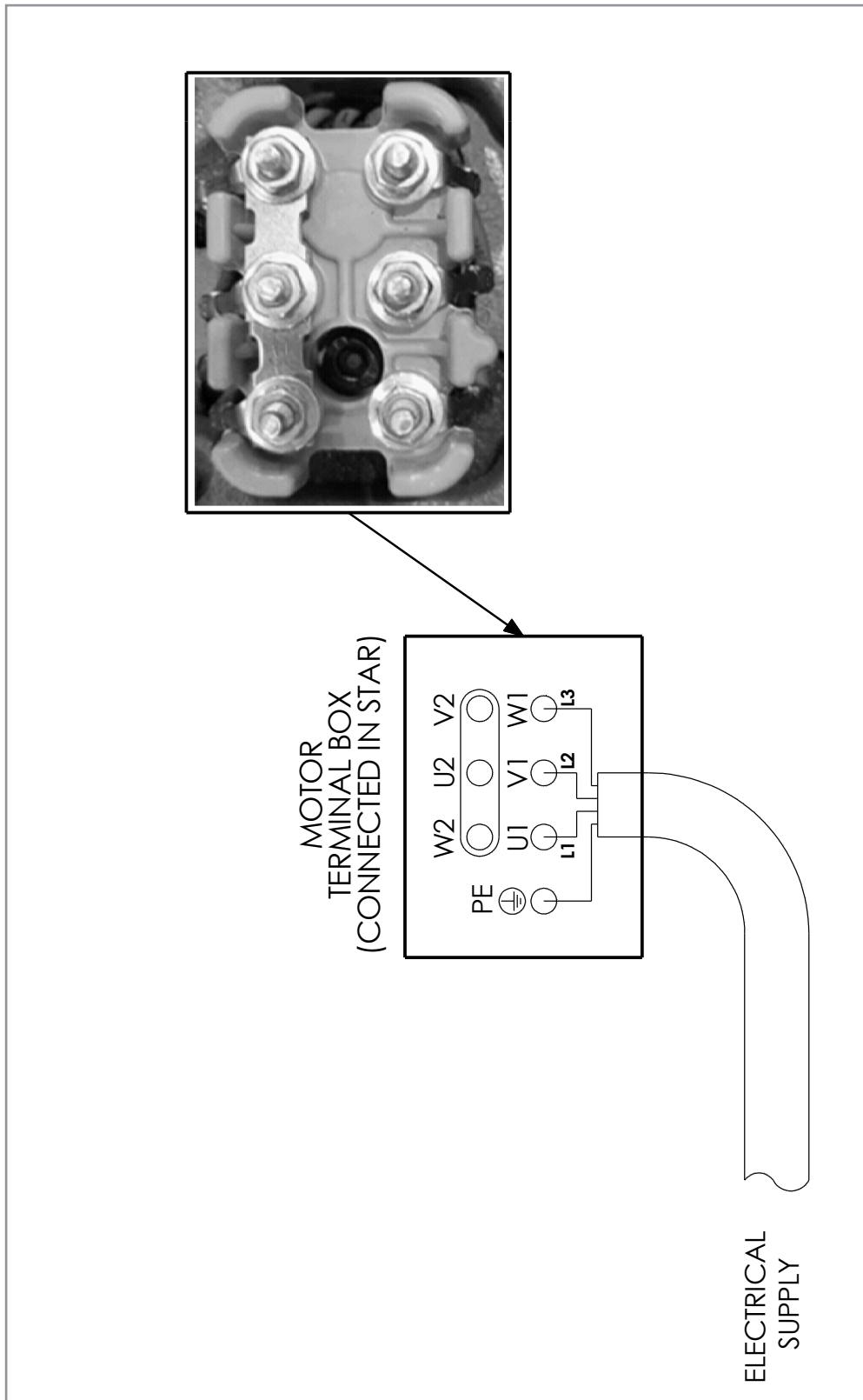
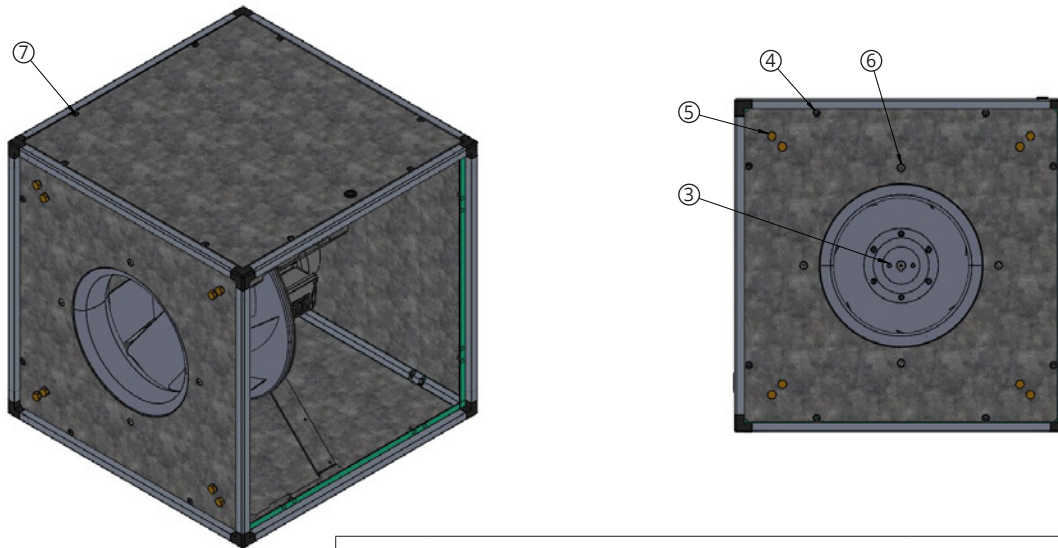

FIGURE 5

TORQUE SETTING FOR FIXINGS



PRODUCT CODES: PB315140, PB315340, PB355340, PB400140, PB315340, PB450140, PB450340

FIXING No.	Description	FIXING SIZE	Torque Nm.
1	Motor Mount Plate to Motor	M10	55
2	Arm to Motor Mount Plate	M10	40
3	Taper Lock Bush	3/8" BSW	20
4	Inlet Plate to Chimney Nut (on Extrusion)	M5	3.5
5	Inlet Plate to Arm	M10	40
6	Inlet Plate to Inlet Bellmouth	M6	12
7	Side Panel to Well/Truss Nut (in Extrusion)	M5	2

PRODUCT CODES: PB500140, PB500340

FIXING No.	Description	FIXING SIZE	Torque Nm.
1	Motor Mount Plate to Motor	M10	55
2	Arm to Motor Mount Plate	M10	40
3	Taper Lock Bush	7/16" BSW	20
4	Inlet Plate to Chimney Nut (on Extrusion)	M5	3.5
5	Inlet Plate to Arm	M10	40
6	Inlet Plate to Inlet Bellmouth	M6	12
7	Side Panel to Well/Truss Nut (in Extrusion)	M5	2

PRODUCT CODES: PB560340, PB630340

FIXING No.	Description	FIXING SIZE	Torque Nm.
1	Motor Mount Plate to Motor	M10	100
2	Arm to Motor Mount Plate	M10	40
3	Taper Lock Bush	7/16" BSW	30
4	Inlet Plate to Chimney Nut (on Extrusion)	M5	6
5	Inlet Plate to Arm	M10	40
6	Inlet Plate to Inlet Bellmouth	M6	12
7	Side Panel to Well/Truss Nut (in Extrusion)	M5	2

NOTES

A series of horizontal dotted lines for writing notes.



Woods Air Movement delivers smart and energy efficient Air Movement and Fire Safety solutions to support every application area. We offer our customers innovative technologies, high quality and outstanding performance.

The widest range of Air Movement and Ventilation products in the market, and strong market presence with over 100 years of experience and manufacturing of products, guarantees that we are always by your side, ready to deliver Excellence in Solutions.

**Contact our friendly sales team today
for more information**

Call: +44 (0) 1206 222 555

Email: quotations.woods@flaktgroup.com

www.woodsairmovement.com

Part Number 916785